





SPREIZKEIL SPK 250 MK2 E-FORCE3

E FORCE 3

ID Nummer
1101981



-  CHARGE
-  360° HANDLE
-  SPEED CONTROL
-  LED LIGHTS

Technische Daten:

Spreizweite	61 mm
Spreizkraft	248 mm
Gewicht (einsatzbereit)	12,9 kg
Abmessungen (LxBxH)	770 x 150 x 241 mm

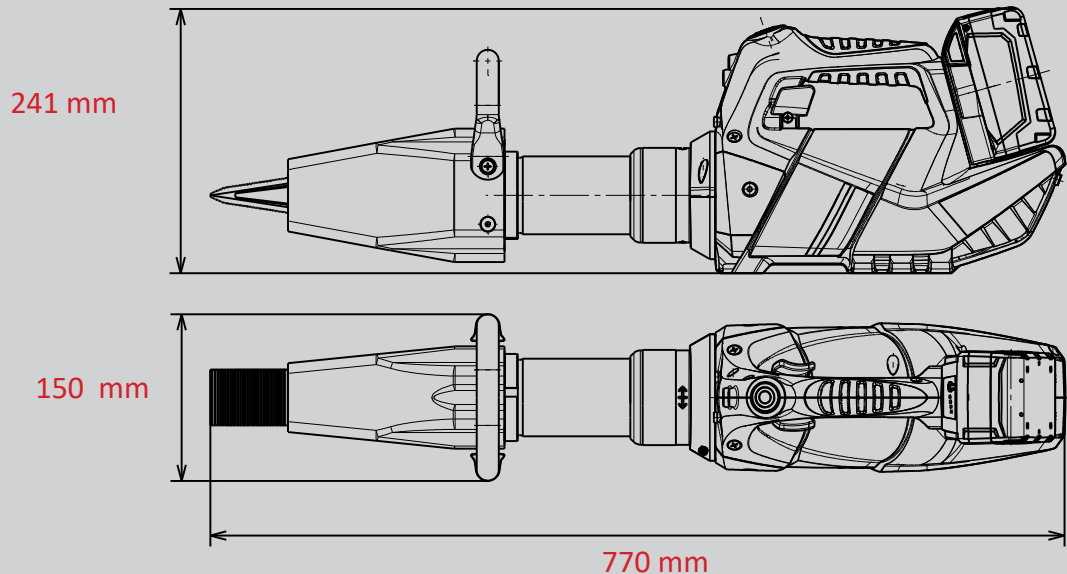

WEBER-HYDRAULIK GMBH
Heilbronner Straße 30
74363 Güglingen/Deutschland
Fon +49 7135/71-10270
Fax +49 7135/71-10396
info@weber-rescue.com

Emil Weber Platz 1
4460 Losenstein/Österreich
Fon +43 7255/6237-120
Fax +43 7255/6237-12461
info@weber-rescue.com

Abbildungen unverbindlich. Technische Änderungen vorbehalten.
10/2023A